

SG-239 Smartuner™ Manual



Cat. #54-22

October 2001



SGC — The SSB People

SGC develops, manufactures, and sells high performance single sideband (SSB) communications equipment. Since 1971, the company has sold to the marine, military, aviation, and industrial markets worldwide. Over these years, SGC has earned an outstanding reputation for product reliability and for after sales service.

The company keeps pace with equipment options, engineering developments, and design requirements. Its products are the most competitive in the entire long distance communication market. SGC equipment is presently being used by the United Nations for inter-communications in developing countries throughout the world.

Many competitive racing vessels, as well as fishing boats, tugs, and commercial craft are equipped with SGC equipment. In fact, an SGC radiotelephone provided the only communications available on a past Polar expedition by the National Geographic Society.

SGC also supplies U.S. government agencies, several foreign governmental agencies, and major petroleum companies throughout Asia and Latin America.

All SGC equipment is designed and manufactured in the USA. SGC has qualified people ready to provide technical information, assistance in selecting equipment, and recommendations for any installation.

SGC welcomes your call to discuss your SSB requirements.

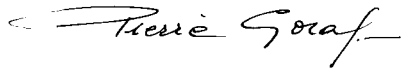

Terrie Graf



Mailing: PO Box 3526, Bellevue, WA 98009

Shipping: 13737 SE 26th St., Bellevue, WA 98005

Toll-Free: 800-259-7331 • Phone 425-746-6310 • Fax: 425-746-6384

www.sgcworld.com • Email: sgc@sgcworld.com

© 2001 SGC, Inc.

Table of Contents

| | |
|-----------------------------------------------------|----|
| Specifications | 5 |
| 1.0 Supplied Items | 6 |
| 2.0 Mechanical Design | 6 |
| 2.1 Marine Mounting | 6 |
| 2.2 Desert and High Temperature Installations | 6 |
| 2.3 Direct Weather Protection Installations | 7 |
| 3.0 Coupler Configuration..... | 7 |
| 3.1 Connections to SG-239..... | 7 |
| 3.2 Tuning Process | 8 |
| 3.3 Impedance Detector..... | 8 |
| 3.4 VSWR Detector..... | 9 |
| 3.5 Phase Detector | 9 |
| 3.6 Central Processing Unit (CPU) | 9 |
| 3.7 Initialization..... | 10 |
| 3.8 Jumper Settings..... | 10 |
| 4.0 Tuning Process and Options | 11 |
| 4.1 Program Description | 11 |
| 4.2 Tuning Paths | 13 |
| 4.2.1 Antenna Too Short | 13 |
| 4.2.2 Antenna Too Long | 14 |
| 4.2.3 JP1—Tuning Elements Out During Receive..... | 14 |
| 4.2.4 JP3—Tune From Memory | 15 |
| 5.0 B.I.T.E. Status LED Descriptions..... | 15 |
| 6.0 Optional SmartLock | 16 |
| 6.1 Tune, Tune Lock, and Reset | 17 |
| 6.2 SmartLock Notes | 17 |
| 7.0 SG-239 Enhanced Features..... | 18 |
| 8.0 Do-It-Yourself Light Bulb Dummy Load..... | 20 |
| 9.0 Five Golden Rules of HF Installation | 22 |
| 10.0 Standard Warranty | 24 |
| 11.0 Component Location..... | 25 |
| 12.0 Schematics..... | 26 |
| 13.0 Smartuner™ Comparison Charts..... | 34 |

This manual is produced as a guideline for the SG-239 antenna coupler. Performance and results may vary and SGC does not warrant any installation or any result. This manual is subject to change without notice.

SG-239

Quick Start

Installation:

To quickly install your antenna coupler you will need the following:

1. An HF radio with 1.5 to 200 watts output.
2. An HF antenna with a wire feed. Minimum length of 9 feet (7-30 MHz @ 100W), 40 feet (3-30 MHz @ 200W) or 100 feet (1.8-30 MHz @ 100W).
3. A good ground radial longer than the antenna for the antenna and coupler.
4. +12 VDC and ground for the coupler.
5. SmartLock coupler controller (optional).

Power supply can be same as the radio or supplied by radio DC switch supply line.

Operation:

1. Turn on Radio. Apply +12 VDC power to the coupler.
2. As power is applied, coupler should make one “click” sound and is in the bypass (un-tuned) state.
3. To tune, speak normally, whistle or use CW (CW is recommended).
4. Tuning should be done at full power for automatic. Clicking is heard.
5. When tuned, clicking stops, the tune LED turns on and output tune line goes low. SG-239 can be tuned manually at any transmit or receive frequency, **five** memory bins are assigned for **receive only**.
6. The coupler PI network can be manually tuned and stored in memory by using switch S1 and pushbuttons S2-S8.

Mailing: PO Box 3526, Bellevue, WA 98009

Shipping: 13737 SE 26th St., Bellevue, WA 98005

Toll-Free: 800-259-7331 • Phone 425-746-6310 • Fax: 425-746-6384

www.sgcworld.com • Email: sgc@sgcworld.com

© 2001 SGC, Inc.

Specifications SG-239

| | |
|---------------------------------|--------------------------------------------------------------------------------------------------------------------------------------------------------------------------------------------------------------------------------------------------------------------------------------------|
| HF Frequency Range: | 1.8-30 MHz |
| Power Input Range: | 1.5-200 watts (PEP) Or CW duty cycle 40% |
| Number of channels: | unlimited |
| Revolving memory bins: | 165 TX; 5 RX |
| Input Impedance Range: | .2-5000 ohms |
| VSWR: | (Typical) Typically less than 2:1 |
| DC Input Requirement: | +13.8 VDC (nominal) |
| DC Operating Range: | +10 to 18.5 VDC |
| Input Current: Average: | 230 milliamps |
| Random set time: | Typical: less than 2 seconds |
| Recurrent set time: | Typical: less than 10 milliseconds |
| Antenna Length: | Minimum length of 9 ft. - 7 to 30 MHz Minimum length of 40 ft.-3 to 30 MHz Minimum length of 100 ft. - 1.8-30 MHz |
| Installation: | Any position |
| Operating Temperature: | -35° to +70°C |
| Size: | 7.5"L x 6"W x 1.85"H (19cm x 15cm x 4.5cm) |
| Weight: | 2 pounds |
| Case Construction: | Irradiated aluminum case |
| Control Cable (not supplied) | Standard coaxial and 2 wires for DC plus 2 wires for optional SmartLock gauge 14-18 |
| Antenna types: | <ol style="list-style-type: none">1. Whip2. Backstay (marine, sail)3. Dipole centerfed4. Dipole with feedline5. Loop (small) 2x2 multi turn6. Loop (large) 10 ft. and up single turn7. Longwire8. Ladder feed |

Specifications subject to change without notice.

1.0 Supplied Items

SG-239 Coupler
Manual
Quick-Start Card

2.0 Mechanical Design

The SG-239 is supplied in an aluminum case with mounting holes. RF and DC power is supplied to the unit through terminals accessible on the outside of the case. The internal construction is designed to withstand the shock and vibration of marine service. Corrosion-resistant hardware and passive alloys are employed throughout. For 99% of installations, the factory settings for jumpers will be correct. The coupler must be installed in an area not directly exposed to the sunshine or rain. Although the Smartuner is built very solidly, it is good installation practice to provide additional protection from the elements. SGC makes the following recommendations:

2.1 Marine Mounting

The Smartuner should be located inside the house or under the aft lazaret on a sailboat installed in a waterproof case. The preferred installation if vertical is with the RF terminals pointing upward. The antenna connects to the screws on the top. The SG-239 may be mounted in any position including inverted without any degradation of performance. To waterproof a SG-239, place the unit in a sealable food container, (1.7 liter - 7 cup standard size)

2.2 Desert and High Temperature Installations

The Smartuner may be used in very hot climates on a continuous basis if some additional protection from direct sunlight is provided and if coupler is installed in a waterproof case. Temperatures inside a vehicle may exceed 212°F (100°C). It is desirable to keep the coupler in the shade if possible.



Mailing: PO Box 3526, Bellevue, WA 98009

Shipping: 13737 SE 26th St., Bellevue, WA 98005

Toll-Free: 800-259-7331 • Phone 425-746-6310 • Fax: 425-746-6384

www.sgcworld.com • Email: sgc@sgcworld.com

© 2001 SGC, Inc.

2.3 Direct Weather Protection Installations

To protect the unit from direct exposure to sunlight and to prevent heavy build up of ice, we recommend installing the Smartuner first in a waterproof case then placing the case under some kind of protective housing. If you are mounting it on a tower in a hot or cold climate, a plastic wastebasket (such as those made by Rubbermaid™) makes an excellent weather cover and costs only a few dollars.

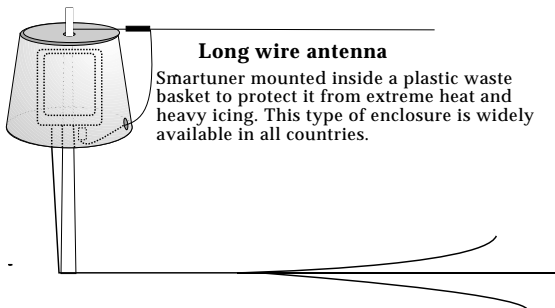

Long wire antenna

Smartuner mounted inside a plastic waste basket to protect it from extreme heat and heavy icing. This type of enclosure is widely available in all countries.

3.0 Coupler Configuration

Schematic Q30102900A, pg. 26, sheet 1 of 6, is the schematic diagram of the two basic coupler networks L & PI. Note that the L network as viewed from the generator, may be configured as either “C in” or “C out,” whichever is required by the load. In either case, the end of the network containing the shunt C element will be the higher impedance end of the network.

3.1 Connections to SG-239

Drawing G30102900A, pg. 26, sheet 1 of 6 and pg. 30, sheet 5 of 6, are the diagrams of the antenna coupler connections. RF input and ground is applied respectively to terminals “RF in” and GND.” The DC input is applied with the positive to the “12V” DC terminal and “GND DC.” The “TND” terminal can be connected to transceiver or SmartLock. This line cannot be connected to both units simultaneously. The Hold/Reset terminal is to be reconnected to the SmartLock option if used.

Mailing: PO Box 3526, Bellevue, WA 98009

Shipping: 13737 SE 26th St., Bellevue, WA 98005

Toll-Free: 800-259-7331 • Phone 425-746-6310 • Fax: 425-746-6384

www.sgcworld.com • Email: sgc@sgcworld.com

3.2 Tuning Process

An array of detector devices in the SG-239 monitor the antenna system impedance, reactance signal, and the VSWR load when RF power is applied to the unit. The coupler also monitors forward power, since the control computer requires an indication of both forward and reflected power in order to allow tuning to proceed. The computer uses the forward power detector as a check to ensure that the measurements made are applied RF and are not spurious levels from the data conversion system. The SG-239 will proceed to tune only when enough forward power is present to confirm this check. After RF is applied to the detector system, it then passes through the coupler tuning array. The coupler tuning array consists of six capacitors in shunt on the input arm of the network, seven inductors in the series arm, and four more capacitors in shunt on the output arm, all arranged in binary increments. Relays are provided in conjunction with each lumped constant and allow removal or entry as desired. A network having 64 values on input shunt C, 16 values of output shunt C, and up to 128 values of series L is possible with the manipulation of these 17 relays.

3.3 Impedance Detector

RF transformers T1 and T3 drive the impedance bridge that is balanced at 50 ohms. T3 samples the line current and thus D7 out-puts a negative DC level proportional to line current. A tertiary winding on transformer T1 provides a line voltage sample to D2 that provides a positive voltage proportional to line voltage. R18 and R11 act as a summing network for the current and voltage signals, with ratios chosen, such that at 50 ohms, the summed signals result in a balanced or zero voltage condition. If the line impedance goes to high, the signal from the voltage sensor will be relatively higher than the current sensor, which will result in a net positive output voltage from the summing network. Similarly, a low line impedance will result in more output from the current sensor, resulting in a net negative output voltage from the summing network. The summing network output is shifted to a 0 to 5v range, then fed to the processor's A to D converter port, and used within the micro-controller.

Mailing: PO Box 3526, Bellevue, WA 98009

Shipping: 13737 SE 26th St., Bellevue, WA 98005

Toll-Free: 800-259-7331 • Phone 425-746-6310 • Fax: 425-746-6384

www.sgcworld.com • Email: sgc@sgcworld.com

© 2001 SGC, Inc.

3.4 VSWR Detector

A directional coupler is made up of a current transformer T2 and a voltage transformer T1, in conjunction with termination resistors R35, R36 and R33, R34. The coupler is inserted in the 50-ohm transmission line between the input connector, ST2 RF - ST3 GND, and the tuning network. The forward power is measured across termination R33, R34 and reflected power is measured across termination R35, R36. Diode D1 generates a positive DC voltage proportional to forward power and D3 generates a positive DC voltage proportional to reflected power. The forward DC output is fed to a voltage divider consisting of R19 and R14. These voltages are input to the RF power detector and to an A to D converter port of the processor. The reflected DC output passes through a voltage divider consisting of R29 and R16, and then it also goes to an A to D converter port of the processor.

3.5 Phase Detector

A phase detector is formed by T3, A1, and their associated components. This detector indicates the state of any reactance associated with the antenna coupler as noted from the generator. A line current sample is compared in phase with a voltage sample in a double balanced mixer. Output polarity varies negative or positive depending on the reactance of the antenna. The output of the phase detector A1 is shifted to a 0 to 5v range, then fed to the processor's A to D converter port and used within the micro controller.

3.6 Central Processing Unit (CPU)

A tune-up algorithm, which is contained in the memory of the microprocessor, implements the antenna matching. It is designed around the MC68HC711E9 CPU that features a versatile instruction set, RAM, and EEPROM (memory which is saved after the coupler is turned off). The antenna coupler relays are controlled by latches U6 and U7, which receive serial data input directly from the CPU. During operation, data is transferred into the CPU from the A to D ports and Input Capture port (measures RF frequency). Basically, the program monitors the status of the input sensors and—starting from a preset condition—uses a built-in algorithm to achieve a tuned condition. When the



tuning algorithm is complete, the CPU saves the settings in its EEPROM, which is addressed by the applied RF frequency. This non-volatile memory table is the basis of the exclusive learning feature of the SG-239. After it has stored and latched the network status, the CPU waits for RF to cease transmitting and returns to the Stop mode. When RF is re-transmitted, the first step in the tuning algorithm is to measure the frequency of the signal passing through the coupler. From the frequency data, the computer then searches its EEPROM for previously stored data. If data is found, it is tested for validity, and the required “end of tune” conditions will be sensed by the RF sensors. Then the data will be latched in place, and the CPU will again wait for RF to cease transmitting and turn to the Stop mode. This process takes about 10 milliseconds, which is the same length of time that is required to close the network relays.

3.7 Initialization

The microcomputer is usually in the Stop mode and requires an interrupt signal (XIRQ) to start program implementation. The XIRQ is obtained from the RF detector circuitry. This line, going low, will wake the CPU from the Stop mode.

3.8 Jumper settings

The SG-239 may be bypassed for broad band (un-tuned antenna) scanning listening in receive mode. All you need to do is press the reset button of the SmartLock (if installed) or turn power to the coupler off and on. When the coupler comes back on, the tuning elements remain out of the circuit until the Smartuner is activated by a transmitted signal. If broad band operation is required during receive for scan operation, jumper JP1 may be set to the Yes position. This will drop the tuning elements out of the circuit on receive only.

Jumper JP1 is located adjacent to MCU (U5) along the edge of the printed circuit board. Setting JP1 to the Yes position is recommended if you are using a radio for split band communications, for scanning selective calling protocols, or for Automatic Link Establishment (ALE). The default is: Tuning Out In Rcv: [NO].

Jumper JP3 bypasses the coupler's memories. This means that each time the coupler is used on a different frequency, it will re-tune

Mailing: PO Box 3526, Bellevue, WA 98009

Shipping: 13737 SE 26th St., Bellevue, WA 98005

Toll-Free: 800-259-7331 • Phone 425-746-6310 • Fax: 425-746-6384

www.sgcworld.com • Email: sgc@sgcworld.com

© 2001 SGC, Inc.

rather than use previously stored information. The default is: Tune From Memory: [YES].

4.0 Tuning Process and Options

MicroTune™ Software
Copyright 1991-2001

The SG-239 MicroTune™ Software is unique software which allows precise tuning of the digitally controlled π and L network to tune a wide variety of antennas. The versatile MicroTune™ software offers its user these special functions:

1. The coupler is activated whenever forward power is present.
2. In addition to sampling VSWR to determine if the coupler should re-tune, frequency comparison is employed. This causes the coupler to tune when ever the transmit frequency changes independent of the VSWR reading.
3. Extensive tuning paths are used to test different antenna situations. The initial tuning of a new frequency (or switched antenna) may require up to two seconds. Any further tuning is accomplished in a matter of milliseconds if jumper JP3 (Tune From Memory) is in its default position.
4. Facilities and algorithms are used which enable accurate tuning at the low end of the frequency band—even on shorter antennas than previously possible.
5. The BITE (Built-In-Test-Equipment) Indicator Tune LED includes a safety feature that alerts the operator to a mismatched condition, with blinking indicators, when proper tuning conditions have not been met. In this situation, the software will “time out” within 20 seconds unless a new frequency is sensed, which will cause an immediate time out, and the coupler will attempt to match the new frequency. The microprocessor of the coupler “wakes up” every time the coupler has forward power. However, re-tuning takes place only if the frequency has changed or the VSWR exceeds 2:1.

4.1 Program Description

When DC power is applied, the computer initializes the processor registers in accordance with the hardware. All tuning elements are then



removed and the 'tune' indicators are turned off. At this time the computer reverts to a "sleep" mode awaiting RF power or pushbuttons S2-S8 in Manual Mode.

4.1.1 Auto Mode

Detecting forward power. Once forward power is detected and the optional SmartLock is switched to Normal, the current coupler settings are sent to the relays. Next, the VSWR is checked and the frequency measured. If the VSWR is greater than 2:1 or a difference in frequency is detected, the program branches to the re-tune program. If it is determined that the VSWR is less than 2:1 and the frequency has not changed, the computer returns to the Stop mode. Re-tuning. Once it is determined that re-tuning is necessary, a test is made to see if JP3 is set to tune from memory. If the result is re-tuning from memory, settings are recalled from the EEPROM based on the frequency measured. The recalled data is then tested for validity. If the data proves invalid, it is bypassed and re-tuning is performed. If the data recalled proves valid, the data is sent to the relays and the VSWR is checked. If the VSWR is less than 2:1, the program branches to the "OK Tuned" section of the program. If the VSWR is found to be greater than 2:1, the program branches to the "re-tune" program.

Selecting tuning path. Several tests are made to determine which tuning algorithm or path should be used to tune the coupler. These tests are based on frequency, antenna input impedance, antenna phase, and VSWR. Numerous subroutines are executed repeatedly, depending on the status of the criteria mentioned above, in order to achieve proper tuning.

Signaling "no-tune." Should the initial primary tuning sequence prove unsuccessful, secondary algorithms are attempted until all possible routines have been exhausted. If, after the secondary attempts, the coupler still cannot achieve a proper VSWR, the program branches to a "no-tune" program. Here, the LED's and remote tune indicator will blink on and off for about 15 seconds to tell the user a proper VSWR could not be found. After the indicators stop blinking,

Mailing: PO Box 3526, Bellevue, WA 98009

Shipping: 13737 SE 26th St., Bellevue, WA 98005

Toll-Free: 800-259-7331 • Phone 425-746-6310 • Fax: 425-746-6384

www.sgcworld.com • Email: sgc@sgcworld.com

© 2001 SGC, Inc.

the program waits for forward power to cease (if it has not ceased already) and returns to stop mode. At this point the user should try several other frequencies. If the “no-tune” condition persists, check the installation of the antenna, coupler, radio, and ground system for possible problems.

Signaling “OK tune.” If the coupler achieves a good VSWR during the tuning sequence, the program branches to the “OK Tune” section of the code. Here, the tune indicators are engaged. A test is then made to check if JP3 is set to tune from memory. If so, the frequency is measured and the tuning elements used are saved in memory coupled with a verification code. Once saved, a test is made on JP1 to check if the duplex mode has been selected. If so, the transmit tuning elements remain in circuit until the receive mode is verified. At this time, all tuning elements are removed. The frequency is then saved for future comparison and the CPU reverts back to the STOP mode.

4.1.2 Manual Mode

Manual Mode allows user to adjust and save settings with or without RF power applied. See section 6 for details on use in manual mode.

4.2 Tuning Paths

As mentioned previously, various tests are executed to determine the most logical tuning sequence to be performed. Dependent on the test results, additional tests and appropriate sub-routines are executed throughout the tuning process. Following are examples of the activity that occurs when the coupler must be matched to a frequency that requires a slightly longer or shorter antenna:

4.2.1 Antenna Too Short

Once coupler has verified RF power, tuning sequence proceeds as follows:

1. Series inductance is added until the phase is deemed as being inductive. At this point it is normal for the input impedance to be low.
2. Input capacitance is added until the antenna is no longer inductive.
3. The program will continue to increment the series inductance in .125 μH steps—each time normalizing the input impedance with

Mailing: PO Box 3526, Bellevue, WA 98009

Shipping: 13737 SE 26th St., Bellevue, WA 98005

Toll-Free: 800-259-7331 • Phone 425-746-6310 • Fax: 425-746-6384

www.sgcworld.com • Email: sgc@sgcworld.com



input capacitance until a low VSWR is measured of less than 2:1. This process will continue until the VSWR has climbed back to higher than 2:1 or the impedance has become high.

4. The settings that gave the lowest VSWR have been kept in memory and are now recalled to verify it is a low VSWR
5. At this point the tune indicators are engaged. The current relay data is saved if JP3 is set to tune from memory; if JP1 is set to tune elements out during receive position, the program waits until forward power is no longer present, then removes all tuning elements. The frequency is saved for future frequency comparison, and the computer reverts to Stop mode.

4.2.2 Antenna Too Long

Once the coupler has verified RF power, the tuning sequence proceeds as follows:

1. Output capacitance is added until the phase switches to capacitive.
2. At this point, series inductance is added until the antenna is no longer capacitive.
3. Fine tuning is performed by trying a small amount of input capacitance (this may or may not be required).
4. At this point, the program executes the same as step 5 (antenna too short).

The preceding gives a simplified program flow on only two possible antenna conditions. Much more complex tuning is normally the case. Further detailed description, however, is beyond the scope of this manual.

4.2.3 JP1—Tuning Elements Out During Receive

(Factory Default Setting: No)

YES - In this position the software will retain data required in transmit to match the coupler while removing all tuning elements when no forward power is detected.

NO - In this position the coupler will retain the required tuning data and will change nothing whether in receive or transmit. If typical operation is out of band duplex, **Yes** would be most likely to give better performance. If in band operation is typical and duplex or sim-

Mailing: PO Box 3526, Bellevue, WA 98009

Shipping: 13737 SE 26th St., Bellevue, WA 98005

Toll-Free: 800-259-7331 • Phone 425-746-6310 • Fax: 425-746-6384

www.sgcworld.com • Email: sgc@sgcworld.com

© 2001 SGC, Inc.

plex is the predominant mode of operation, then **No** is usually the better choice.

4.2.4 JP3—Tune From Memory

(Factory Default Setting: **Yes**)

YES - In this position the coupler will recall data previously saved and try this data before attempting to re-tune. If the data is valid and the VSWR is less than 2:1 the tune is completed. In this position the coupler will save any new data in its memory for any frequency. A new frequency must first be learned, while in this mode, before it can be recalled.

NO - In this position, the coupler will not use previously saved tuning data. Each time a different frequency is selected, the coupler will proceed through a complete tuning sequence. Clearly, the advantage of **Yes** is speed. The coupler will seem to be matched instantly when in this position, if the frequency being used has previously been saved in EEPROM. Disadvantages include a difference in frequency too small for the computer to detect. This would result in recall of valid data that may not necessarily present the best match. We suggest starting with JP3 in the **Yes** position. If operation is as expected, don't change it.

5.0 B.I.T.E.* Status LED Descriptions

*Built In Test Equipment

TND

This LED will light when the tuner has found an acceptable match. It will remain lit until conditions have changed which will cause the tuner to find a different match. (i.e. A new transmit frequency has been detected, or tuner has been reset.)

L'Z'

This LED shows the status of the antenna impedance. When lit, the impedance is 50 ohms or less. When off, the impedance is greater than 50 ohms.

2:1

This LED will light when the VSWR is greater than 2:1. It will extinguish when VSWR is less than 2:1.

PHZ

This LED indicates the status of the antenna reactance. When lit, reactance is inductive. When off, reactance is capacitive.

FWD

This LED indicates the presence or lack of RF power from the radio. When transmitting, the LED will light to indicate RF is being detected. In receive, the LED should be extinguished.

OTHER

All LEDs will blink on and off at a rate of 2Hz to indicate the tuner was not able to find a valid match.

Note that these status LEDs are usually used to aid a technician in diagnosing the status of the antenna system and should not be thought of as laboratory instruments.

As the Smarttuner tunes, the BITE status will be continually updated from the CPU.

6.0 Optional SmartLock

The SmartLock allows the operator to have additional control over the SG-239. It is not required for normal operation of the coupler. One can be purchased by SGC or made per the description of the schematic in paragraph 5.2. The SmartLock provides two basic functions:

1. To lock the coupler in the last tune mode regardless of any changes made by the operator on the transceiver or external changes that may have occurred on the antenna. It is a very convenient function especially for instable antennas (such as whip antennas on a car in motion) or instable situations due to a system installation or configuration. However, using it in this mode may be hazardous as the

Mailing: PO Box 3526, Bellevue, WA 98009

Shipping: 13737 SE 26th St., Bellevue, WA 98005

Toll-Free: 800-259-7331 • Phone 425-746-6310 • Fax: 425-746-6384

www.sgcworld.com • Email: sgc@sgcworld.com

© 2001 SGC, Inc.

operator may change frequency and the coupler will not tune. It may eventually burn coils and/or relays.

2. Reset function is convenient to force a reset in situations where a coupler will not retune. For example, the last tune achieved on 14.100 with VSWR 1:1.7, the coupler is instructed not to retune until it reaches 1:2.0 - If the coupler is reset and therefore will retune at your next transmission it may tune to 1:1.1 or much better before the last read of 1:1.7 - reset can also be used to listen to other frequencies out of band of your last setting in a broad band mode, and therefore increasing your incoming receive level by several "S" units. Reset is also accomplished by turning power off and on again.

6.1 Tune, Tune Lock/Reset

Tuned (green LED)

Turns on when the coupler has successfully tuned.

Normal/Tune Lock

Toggle switch which allows user to prevent coupler re-tuning by switching to the Tune Lock position. When in the Tune Lock position, the red LED blinks to notify the user that the coupler is locked on the current setting.

Reset

Pushing the red reset button allows the coupler to be reset, if the toggle switch is in the normal position. This is preferred over turning the input power off and on.

6.2 SmartLock Notes

The Tune Lock function is in most cases unneeded. Inadvertent retuning is a rare occurrence. Retuning may occur when the environment or antenna system has changed. In this case, retuning is within normal operation of the coupler.

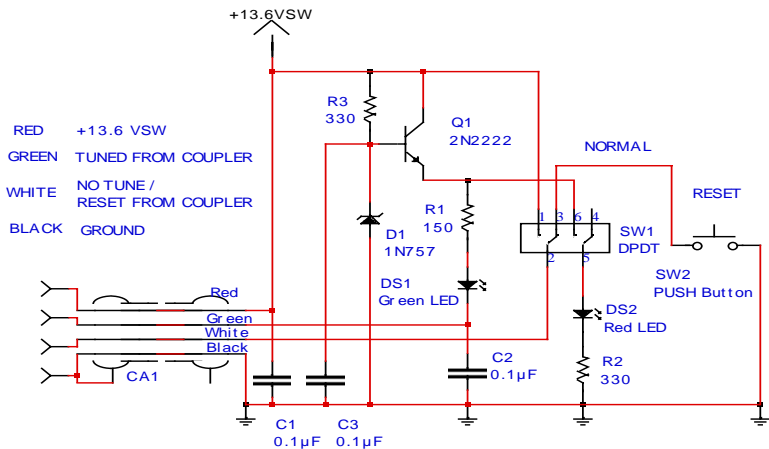

7.0 SG-239 Enhanced Features

1. Clear (Erase) all 170 memory bins
 - A. Set Auto-Manual slide switch position to AUTO.
 - B. Remove DC power from SG-239
 - C. Depress both 'Cin Up', (S3) and 'Cout Dn', (S8). Keep both depressed for next step (Step D).
 - D. Apply DC power to SG-239. In less than one second, all status LED's will start to flash on and off.
 - E. Once LED's start flashing, memory will have been erased and S3 and S8 can be released.

End of procedure

2. Clear single unit memory bin
 - A. Set auto-manual slide switch position to auto.
 - B. Transmit on frequency to recall desired memory bin.
 - C. Switch the transceiver to receive mode.
 - D. Set auto-manual slide switch position to manual.
 - E. Momentarily depress 'SAV', (S2).
 - F. Return auto-manual slide switch position to auto.
 - G. Momentarily depress 'SAV' (S2). Current memory bin has been erased.

End of procedure

3. Manual tuning in transmit

- A. Set auto-manual slide switch position to manual.
- B. Engage transmitter. Not more than 10-15 watts is recommended to avoid accidental RF burn.
- C. Use S3 thru S8 to tune the SG-239. Each time a switch is depressed, the status LED's are updated.
- D. You may save the settings for this frequency by momentarily depressing 'SAV', (S2) while transmitting.

End of procedure

4. Manual tuning in receive - "*Silent Tuning*"

- A. Set auto-manual slide switch position to manual.
- B. Engage receiver.
- C. Use S3 thru S8 to adjust for best receive signal. Note: Status LED's are not updated in receive.
- D. See appropriate procedures for saving and recalling receive only memories (below in paragraphs 5 & 6).

End of procedure

5. Saving a receive only setting into memory

- A. Set auto-manual slide switch position to manual
- B. Momentarily depress 'SAV', (S2) the current RX memory channel will be displayed with the status LED's. (Far left LED is channel 1). If no LED is lit, current channel is zero.
- C. Select desired channel with S3 (Chan Up) and S8 (Chan Dn). Current channel selected is updated as switches are depressed.
- D. Momentarily depress 'SAV' (S2) and current settings will be saved to displayed RX memory bin. Note: Saving to channel zero aborts save.

End of procedure

6. Recall receive only channel from memory

- A. Set auto-manual slide switch position to auto.
- B. Momentarily depress 'SAV', (S2) the current RX memory channel will be displayed with the status LED's. (Far left LED is channel 1). If no LED is lit, current channel is zero. (recall channel zero aborts recall)
- C. Select desired channel with S3 (Chan Up) and S8 (Chan Dn). Current channel selected is updated as switches are de-

Mailing: PO Box 3526, Bellevue, WA 98009

Shipping: 13737 SE 26th St., Bellevue, WA 98005

Toll-Free: 800-259-7331 • Phone 425-746-6310 • Fax: 425-746-6384

www.sgcworld.com • Email: sgc@sgcworld.com

pressed.

D. Momentarily depress 'SAV' (S2) and saved settings will be recalled from displayed RX memory bin.

End of procedure

Additional Notes:

Note 1: Saving and recalling receive only memories

The two procedures are basically the same with the exception of the auto-manual slide switch.

| | |
|---------------|--------|
| SET TO MANUAL | SAVE |
| SET TO AUTO | RECALL |

Note 2: Fine tuning a transmit frequency

Auto tune the frequency as normal.

Switch auto-manual to manual

Fine tune settings with S3-S8

While transmitting, depress 'SAV' (S2) to update transmit memory bin.

8.0 Do-It-Yourself Light-Bulb Dummy Load

Any time that a transmitter is used, it must be outputting into a load. A load is anything that the output power can be pumped into. If the transmitter is operated without any sort of load connected, the final amplifier stage could become severely damaged. The problem is that you should never test a transmitter on the air for the first time, if you are unsure about how to operate it, and if you are unsure whether it is working properly. You could create harmful interference to other stations.

To test transmitters without actually operating into an antenna, dummy loads were created. A dummy load is a load that will dissipate the energy from the transmitter instead of emanating it into the ionosphere. Nearly all commercial dummy loads are large oil-filled cans. These dummy loads change the transmitted energy into heat, which is absorbed by the oil. Because different transmitters output different amounts of power, different sizes of dummy loads must be used. Dummy loads for typical amateur powers (<500 watts) are relatively inexpensive and are readily available.

Mailing: PO Box 3526, Bellevue, WA 98009

Shipping: 13737 SE 26th St., Bellevue, WA 98005

Toll-Free: 800-259-7331 • Phone 425-746-6310 • Fax: 425-746-6384

www.sgcworld.com • Email: sgc@sgcworld.com

© 2001 SGC, Inc.

Unfortunately, when you use a can-type dummy load, you can't see "what's happening" with your transmitter. In this case, you can use a light-bulb dummy load to test your transmitter. Here, the light bulb is directly connected to the output of the transmitter and it dissipates the RF energy as light. The light bulb dummy load is more useful than the oil-can type because you can guess how much power is being output, you can see the voice modulate the SSB (the light will flicker with your voice peaks), and you can tune the transmitter for maximum output (if the transmitter is an older model that requires tuning).

Before building or using the light-bulb dummy load, remember that these models typically don't dissipate the transmitter's output as well as an oil-can dummy load. The result is that RF will "leak" out; we have heard a few stories of amateurs who were heard around town while operating their transmitters into a light-bulb dummy load. If you use this system, make sure that you test the equipment on a clear, harmless frequency (NEVER test with the transmitter set on an emergency frequency, such as 2182 KHz).

SGC recommends that you build the light-bulb dummy load with the following parts (although we have made one with an old light fixture and a makeshift version with just alligator clip leads and a light bulb):

- * AC socket to cable with a PL-259 connector (for transceiver)

- * AC socket to cable with alligator clips (needed with coupler)

- * Light bulb to AC adapter

- * 75 to 125 watt light bulb, 120 to 220 VAC

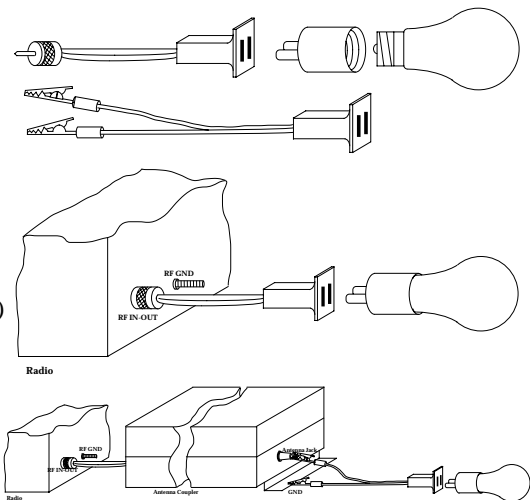

Mailing: PO Box 3526, Bellevue, WA 98009
 Shipping: 13737 SE 26th St., Bellevue, WA 98005
 Toll-Free: 800-259-7331 • Phone 425-746-6310 • Fax: 425-746-6384
 www.sgcworld.com • Email: sgc@sgcworld.com

- * 100 watt radio transceiver
- * Any SGC Smartuner or equivalent

RADIO TEST PROCEDURE

1. Connect the transceiver light bulb load to the radio RF in/out jack.
2. Turn on the radio and set the CW mode.
3. Key the PTT switch on the microphone and look at the light bulb. If the light bulb load is connected and the radio is transmitting, the light should turn on.
4. Set the radio to SSB mode.
5. Key the PTT switch on the microphone and talk into the microphone. Notice that the light turns on when you talk.

COUPLER TEST PROCEDURE

1. Connect the coupler to the radio.
 2. Connect coupler light bulb load to Smartuner coupler antenna output.
 3. Turn on the radio and the Smartuner coupler.
 4. Set the radio to the CW mode.
 5. Key the PTT switch on the microphone and look at the light bulb. The light should turn on if the coupler has completed its' tuning cycle and if the radio is transmitting.
 6. For further testing, follow steps 4 & 5 of the radio test procedure.
- Note: The light bulb might not turn on immediately if the coupler has not yet been tuned for the frequency of the transmitter. The output power (light-bulb brightness) is greatest when the coupler is properly tuned.

This test will ensure that the radio and coupler are working properly.

9.0 Five Golden Rules of HF Installation

These rules apply to all types of stations, including base, mobile, airborne and marine. They are very important for planning and installing your HF system, if you want to achieve good communications.

1. Install transceiver as close to operation site and power supply system as possible (whether it is an external power supply or battery system).
2. The antenna must be installed in an open space and as far as possi-

Mailing: PO Box 3526, Bellevue, WA 98009

Shipping: 13737 SE 26th St., Bellevue, WA 98005

Toll-Free: 800-259-7331 • Phone 425-746-6310 • Fax: 425-746-6384

www.sgcworld.com • Email: sgc@sgcworld.com

© 2001 SGC, Inc.

ble from your operating point. Example, on a sailboat, use the backstay as the antenna, since it is the farthest point away from the rest of the vessel.

3. The antenna coupler must be installed at the base of the antenna.
4. Always create your own ground with radial wire or copper straps. They are the only ones that will guarantee a solid and proper ground system.
5. All cables - power supply, control or coaxial - must always be as short as possible and/or necessary. Any excess cable should be shortened to the proper length - never coiled.

Following these rules will minimize marginal installations and problem sources such as RF feedback in the radio, power supply or cables and "hot" or RF burning microphones. If all 5 above points are followed during the design and installation of your HF system, the operator can expect top performance. Further information regarding applications, installation and operation can be downloaded from our website www.sgcworld.com. These publications include:

- HF User's Guide
- Go Mobile at 500 Watts
- Stealth Antennas
- Smartuner Antenna Coupler Manuals

This manual is produced as a guideline for the SG-239 antenna coupler. Performance and results may vary and SGC does not warrant any installation or any result. This manual is subject to change without notice.

**SGC LIMITED PRODUCT WARRANTY
(1 Year Parts and Labor)
And SOFTWARE LICENSE**

You have purchased an SGC equipment product together with a license to use the software installed in that product. Please return the warranty registration card that accompanies this product, so that we can assure that you receive proper warranty service and important notices that may affect the product. This SGC product is warranted to be free from defects in workmanship and material for a period of 1 year from the original buyer's date of purchase. In the event of a defect, malfunction or failure of which SGC receives notice during the 1 year period, SGC, at its' option, will repair or replace the product free of charge to the buyer. The buyer must contact SGC for a Return Material Authorization Number (RMA) and deliver the product back to SGC with this RMA number and written proof as to date of purchase. SGC will ship a new or repaired product to the buyer, reserving discretionary right to return a newer model that offers at least equal performance. The foregoing warranty extends to the original buyer and does not include (a) buyer's cost to return the product to SGC, (b) buyer's costs to remove or reinstall the product for warranty work, or (c) added costs of special expedited shipment that may be requested by buyer. Except for the limited warranty stated above, and to the full extent permitted by law, SGC disclaims any other express or implied warranties and liability for any incidental, consequential, special or exemplary damages in connection with its product, even if SGC or its agents are advised that such damages are foreseeable. (Note: Some states do not allow the exclusion or limitation of incidental or consequential damages, so the above exclusion may not apply to you). There is no warranty with respect to (a) the product's transmission range or geographical coverage which can vary by location (b) non-performance caused by using an inadequate or improper antenna or grounding system or (c) routine maintenance, periodic adjustment and performance testing of the product or system. SGC customarily charges a flat fee for repairs performed outside of the warranty coverage. To inquire about such charges, please contact SGC.

END USER SOFTWARE LICENSE

SGC warrants that the SOFTWARE included in this product will perform in substantial accordance with the documentation. SGC grants to the original end user of its product a non-exclusive worldwide license to operate the software installed therein. This license shall be transferred to any person or entity that subsequently acquires lawful ownership of the product. This license shall be limited to using the software for contemplated operation of SGC's product. This license does not permit any end user to (a) modify or adapt SGC's software or to merge it into another program (b) reverse engineer, disassemble, or otherwise attempt to discover SGC's software source code or (c) sub license or otherwise transfer SGC's software for any use other than operating the product originally purchased from SGC.

Mailing: PO Box 3526, Bellevue, WA 98009

Shipping: 13737 SE 26th St., Bellevue, WA 98005

Toll-Free: 800-259-7331 • Phone 425-746-6310 • Fax: 425-746-6384

www.sgcworld.com • Email: sgc@sgcworld.com

© 2001 SGC, Inc.

11.0 Component Location

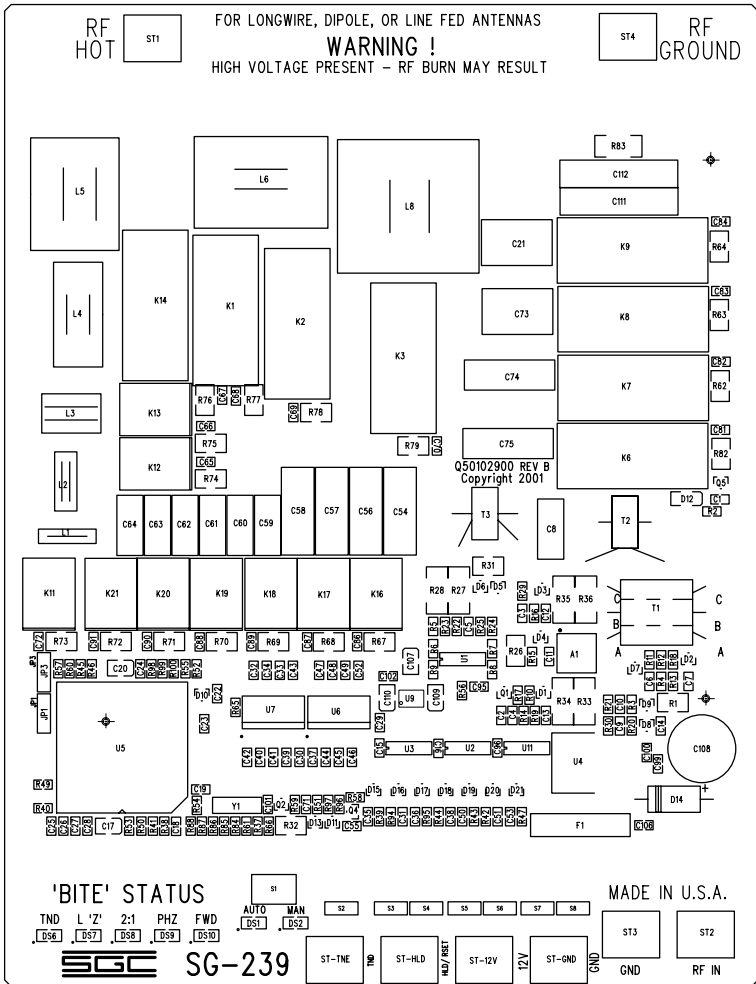

PCBLAYER
 SILKSCREEN TOP

Mailing: PO Box 3526, Bellevue, WA 98009
 Shipping: 13737 SE 26th St., Bellevue, WA 98005
 Toll-Free: 800-259-7331 • Phone 425-746-6310 • Fax: 425-746-6384
 www.sgcworld.com • Email: sgc@sgcworld.com

12.0 Schematics

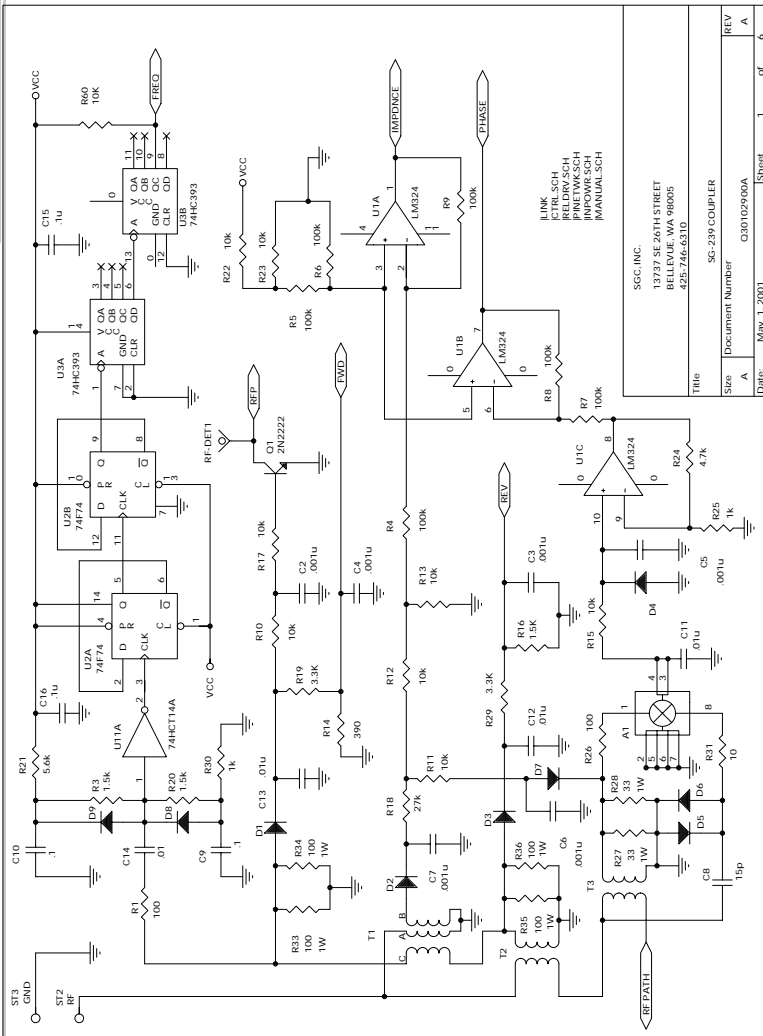

LINK
 HELLOR.SCH
 HELLOP.SCH
 PINETWS.SCH
 INPOWER.SCH
 IMANUAL.SCH

SGC, INC.
 13737 SE 26TH STREET
 BELLEVUE, WA 98005
 425-746-6310

TH16
 S6-239 COUPLER

| | | | | | | |
|------|-----------------|-------------|-------|---|----|---|
| Size | Document Number | C301029/00A | Sheet | 1 | of | 6 |
| REV | Date: | May 1, 2001 | | | | |

Mailing: PO Box 3526, Bellevue, WA 98009

Shipping: 13737 SE 26th St., Bellevue, WA 98005

Toll-Free: 800-259-7331 • Phone 425-746-6310 • Fax: 425-746-6384

www.sgcworld.com • Email: sgc@sgcworld.com

© 2001 SGC, Inc.

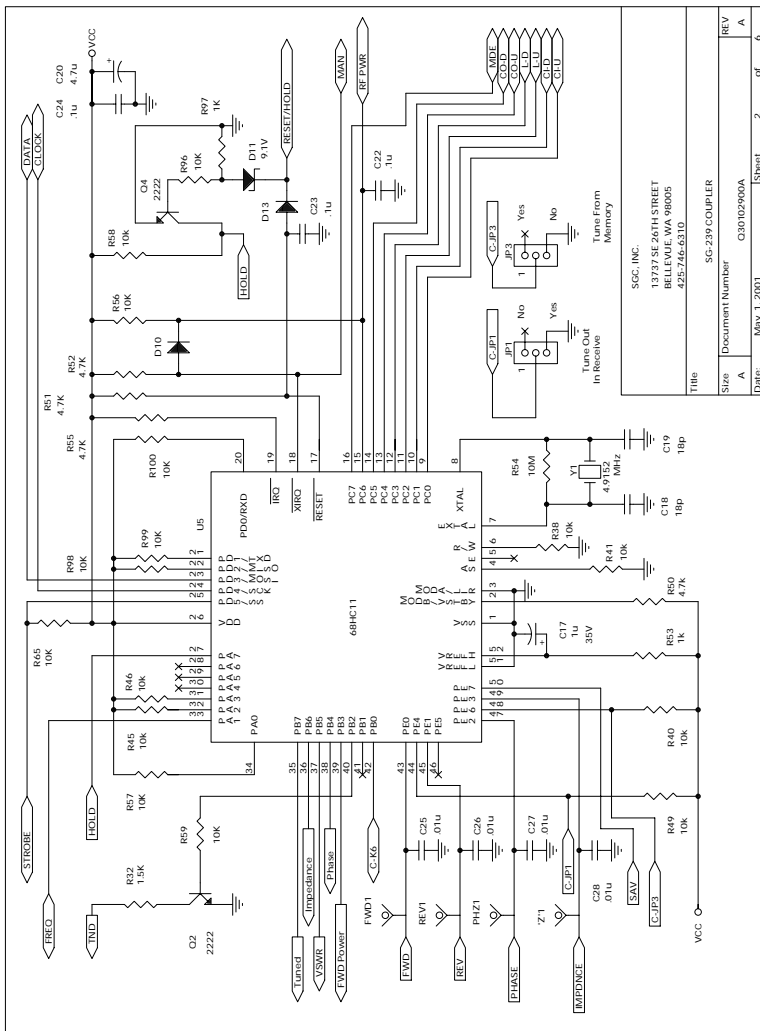

SGC, INC.
 13737 SE 26TH STREET
 BELLEVUE, WA 98005
 425-746-6310

Title: SGC-239 COUPLER
 Document Number: Q30102900A
 Date: May 1, 2001
 Sheet: 2 of 6

Mailing: PO Box 3526, Bellevue, WA 98009
 Shipping: 13737 SE 26th St., Bellevue, WA 98005
 Toll-Free: 800-259-7331 • Phone 425-746-6310 • Fax: 425-746-6384
 www.sgcworld.com • Email: sgc@sgcworld.com

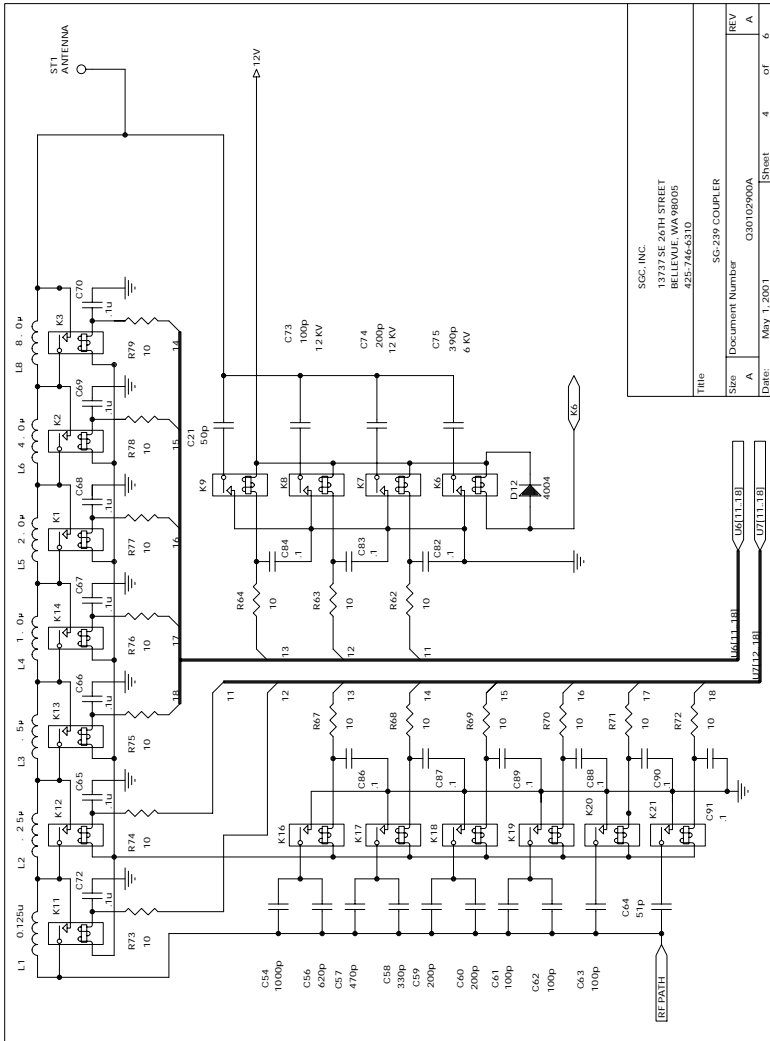

SGC, INC.
13737 SE 26TH STREET
BELLEVUE, WA 98005
425-746-6310

Title: SC-239 COUPLER
Document Number: Q30102900A
Date: May 1, 2001

Size: A
Sheet: 4 of 6
REV: A

Mailing: PO Box 3526, Bellevue, WA 98009
Shipping: 13737 SE 26th St., Bellevue, WA 98005
Toll-Free: 800-259-7331 • Phone 425-746-6310 • Fax: 425-746-6384
www.sgcworld.com • Email: sgc@sgcworld.com

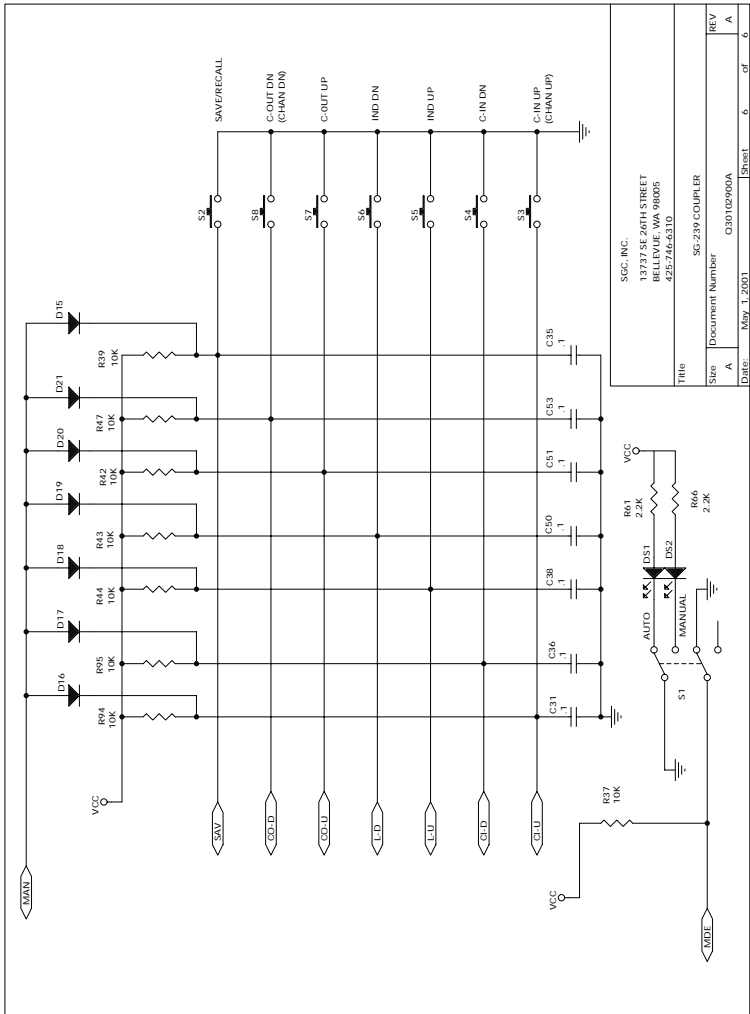

| | |
|-------------------------------------------------------------------------|-------------------------------|
| SGC, INC. 13737 SE 26TH STREET BELLEVUE, WA 98005 425-746-6310 | |
| Title | SGC-239 COUPLER |
| Size | Document Number Q30102900A |
| Date | May 1, 2001 |
| Sheet | 6 of 6 |
| REV | A |

Mailing: PO Box 3526, Bellevue, WA 98009
 Shipping: 13737 SE 26th St., Bellevue, WA 98005
 Toll-Free: 800-259-7331 • Phone 425-746-6310 • Fax: 425-746-6384
 www.sgcworld.com • Email: sgc@sgcworld.com





SG-239 HF Smartuner™

Catalog Number 54-22

SPECIFICATIONS:

| | |
|--------------------|----------------------|
| Power (max): | 200 Watts PEP or CW* |
| Power (typ): | 1.5 Watt PEP or CW* |
| Range ≥9ft. Ant. | 7-30MHz @ 100W |
| Range ≥40ft. Ant. | 3-30MHz @ 200W |
| Range ≥100ft. Ant. | 1.8-30MHz @ 100W |
| Input Voltage: | 12.6 VDC (nominal) |
| Voltage Range | 10 - 18.5 VDC |
| Impedance Range | .2 - 5000 ohms |
| Low Current Drain | Typical 230 mA |

ANTENNAS:

- Whip
- Backstay (marine, sail)
- Dipole centerfed
- Dipole with feedline
- Loop (small) 2x2 ft. multi turn
- Loop (large) 10 ft. and up single turn
- Longwire



IMPORTANT NOTES:

- The SG-239 universal coupler is designed for use with ANY HF transceiver or ANY antenna as specified. All installation configurations are possible such as base stations, mobile, marine, aviation, and small vehicles including motorcycles and ATV'S.
- Only 12 Volt DC and RF connections are required for basic operation. Additional connections are supplied for user specific applications.
- WARNING! High voltage is present on antenna terminal. Avoid contact or RF burns may occur.
- For end fed antennas, use a ground system of several radials which are electrically longer than the radiating portion of the antenna. Radials assure a stable, reliable and electrically 'quiet' ground system, free from electrical noise and RF pollution. Do not use hand rails, metal roofing or ground stakes for a ground system as they are generally contaminated and unstable.
- The SG-239 can be used next to your transceiver as a RF line feed trimmer for balanced or unbalanced lines of 100-1000 ohms or coaxial lines (25-100 ohms). The unit does not require a balanced transformer to perform efficiently.
- For best system and operation efficiency, we recommend installing your antenna in the open and far away from your operating point. Put the Smartuner as close as possible to the base of your antenna system.

* For 40% Duty Cycle

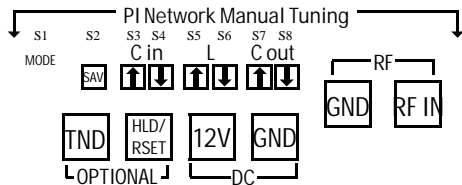

Notes:



Application Chart

| Model | SG-239 | SG-237 PCB | SG-237 | SG-237 Porta | SG-230 | SG-231 | SG-235 |
|-------------------------------------------|---------------|-----------------------|---------------|-------------------------|---------------|-----------------|---------------|
| Introduction Year | 2001 | 1999 | 1999 | 1999 | 1987 | 1995 | 1992 |
| SGC Catalog Number | 54-22 | 54-19 | 54-18 | 54-20 | 54-12 | 54-17 | 54-15 |
| Marine | | | x | | x | x | x |
| Commercial | | x | x | | x | x | x |
| Radio Amateur | x | x | x | | x | x | x |
| Aviation | x | | x | | x | x | |
| Special Applications | x | x | | x | | | x |
| Portable | x | | x | x | | x | |
| Power Input Range (PEP Watts) | 1.5-200 | 3-100 | 3-100 | 3-100 | 3-200 | 3-100 | 3-500 |
| HF Frequency Range | 1.8-30 MHz | 1.8-60 MHz | 1.8-60 MHz | 1.8-60 MHz | 1.6-30 MHz | 1-60 MHz | 1.8-30 MHz |
| Total combinations of elements | 1/8 million | 1/2 million | 1/2 million | 1/2 million | 1/2 million | Four million | 1/2 million |
| Suggested Retail | \$249.95 | \$249.95 | \$359.95 | \$595.00 | \$595.00 | \$595.00 | \$1595.00 |

| Description | SG-239 | SG-237 | SG-230 | SG-231 | SG-235 |
|------------------------------------------------------------------------------------------------------------------------|-------------------------------------|--------------------------------------------------------------------------------------|-----------------------------------------------------------------------------------|---------------------------------------------------------------------------|------------------------------------------------------------------------------------|
| HF Frequency Range | 1.8 - 30MHz | 1.8 - 60MHz | 1.6 - 30MHz | 1 - 60MHz | 1.8 - 30MHz |
| Power Input Range (PEP) | 1.5 - 200 | 3-100 | 3-200 | 3-100 | 3-500 |
| Cont. CW Power (watts) | 80 | 40 | 80 | 60 | 200 |
| Input Impedance Range | 45-55 | 45-55 | 45-55 | 45-55 | 45-55 |
| VSWR (Typical) | <2:1 | <2:1 | <2:1 | <1.4:1 | <2:1 |
| DC Input Requirement | 13.8 | 13.6 | 13.6 | 13.6 | 13.6 |
| DC Op. Range (VDC) | 10 to 18.5 | 10 to 18 | 10 to 18 | 10 to 18 | 10 to 18 |
| Input Current (avg. amps) | 0.23 | 0.3 | 0.9 | 0.5 | 1.4 |
| Random Set Times (sec) | <2 | <4 | <2 | <4 | <2 |
| Recurrent Set Times (ms) | <10 | <10 | <10 | <10 | <10 |
| Non-Volatile Memory | 170 | 170 | 170 | 170 | 170 |
| Total combinations using | 1/8 million | half million | half million | four million | half million |
| Antenna Length operating | 40 feet min. | 8 feet min. | 8 feet min. | 8 feet min. | 23 feet min. |
| Antenna Length operating from the lowest frequency | 100 feet min. | 28 feet min. | 23 feet min. | 23 feet min. | 150 feet min. |
| Elements configuration | Pi & L | Pi & L | Pi & L | Pi & L | Pi & L |
| Input Capacitance min. | 50pf | 50pf | 100pf | 50pf | 100pf |
| Input Capacitance max. | 3150pf | 6400pf | 6400pf | 6400pf | 6400pf |
| Inductance minimum | 0.125µH | 0.125µH | 0.25µH | 0.125µH | 0.125µH |
| Inductance maximum | 15.875µH | 32µH | 64µH | 64µH | 32µH |
| Output Capacitance min | 50pf | 12.5pf | 25pf | 12.5pf | 12.5pf |
| Output Capacitance max | 740pf | 200pf | 800pf | 400pf | 400pf |
| Installation | Any position | Any position | Any position | Any position | Any position |
| Operating Temperature | -35C to +70C | -35C to +70C | -35C to +70C | -35C to +70C | -35C to +70C |
| Environmental | None | Waterproof at immer- | Waterproof at immer- | Waterproof at immersion of | Waterproof at immersion of |
| Size Overall | 7.5"Dx6"Wx1.85"H (19cmx15cmx5cm) | 6"Dx7"Wx1.5"H (23cmx18cmx4cm) | 16"Dx12"Wx3"H (41cmx31cmx8cm) | 11.5"Dx9.5"Wx1.7"H (29cmx24cmx4cm) | 16"Dx12"Wx3"H (41cmx31cmx8cm) |
| Weight | 2 lbs. (0.75kg) | <2 lbs. (<0.75kg) | 8 lbs. (3.5kg) | 3.8 lbs. (1.6kg) | 8 lbs. (3.5kg) |
| Case Construction | Aluminum case | Plastic ABS Waterproof case | Plastic ABS Waterproof case | Plastic ABS Waterproof case | Plastic ABS Waterproof case |
| Cable(s) (NOTE: All couplers require RF and 12 volt lines only. SGC cables are required for additional features only.) | Terminals | SGC cable, 9 feet coaxial and two power wire input, and RMT tune and SmartLock wire. | SGC cable, 9 ft coaxial and two power wire input, and RMT tune and SmartLock wire | 10 feet RG-58 power cable, 10 feet RG-58 coax cable with PL259 connectors | SGC cable, 9 ft coaxial and two power wire input, and RMT tune and SmartLock wire. |



SG-239 SMARTUNER™



Cat. #54-22

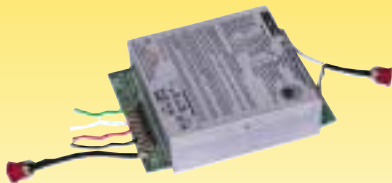

Antenna Coupler



Selected Antenna Configurations

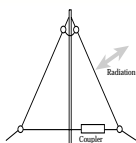

Base Delta Loop

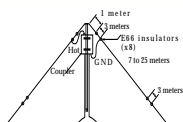

RF Cable Control cable
Base Dipole Installation

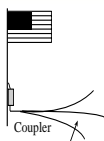

At least three ground radials
longer than the flag pole

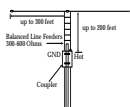

RF cable Control cable
Base Ladder Installation

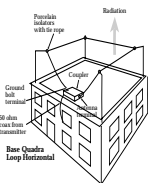

Base Quadra
Loop Horizontal

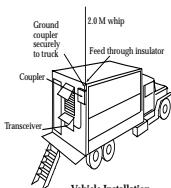
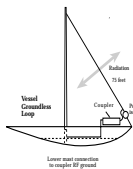

Vehicle Installation



Use a separate ground strap or wire for the body and the chassis to the ground of the coupler.



Fixed Wing Aircraft

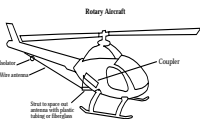

Rotary Aircraft

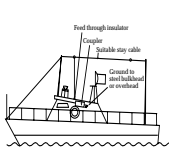

Masthead Veeed Gamma Loop

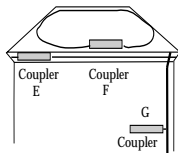

This manual is available for download at
www.sgcworld.com